

Dla wymiarów zewnętrznych obowiązują tolerancje dodatnie. Dla wymiarów wewnętrznych obowiązują tolerancje ujemne.

TABELA WYMIARÓW NIETOLEROWANYCH [mm] wg. ISO 2768-1 m

Wymiar	0,5 - 3	3 - 6	6 - 30	30 - 120	120 - 400	400 - 1000	1000 - 2000	2000 - 4000	Wymiar fazy	0,5 - 3	3 - 6	6 - 30
Tolerancja	$\pm 0,1$	$\pm 0,1$	$\pm 0,2$	$\pm 0,3$	$\pm 0,5$	$\pm 0,8$	$\pm 1,2$	± 2	Tolerancja	$\pm 0,2$	$\pm 0,5$	± 1

IMIĘ I NAZWISKO	PODPIS	MODEL:
Narysował	<i>Chodysz</i>	NAZWA: RAMA BLATU
A3	NR KTM:	SKALA: 1:4
	NR RYSUNKU:	DATA 2019-09-24
		ARKUSZ 1 z 1

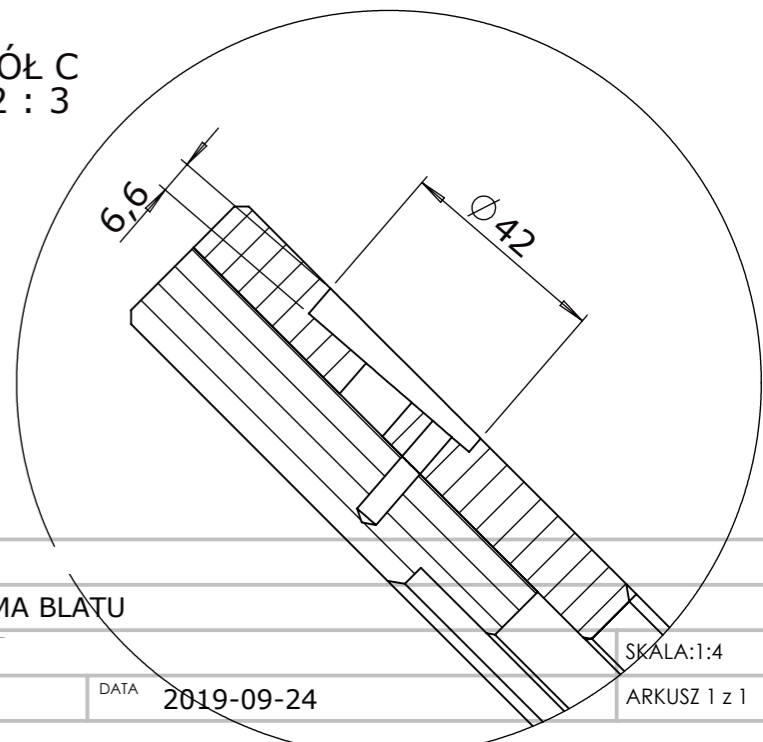

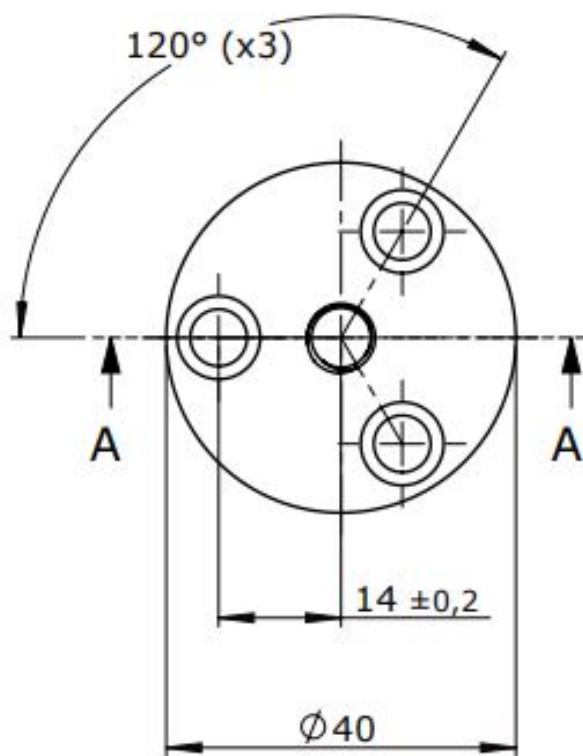
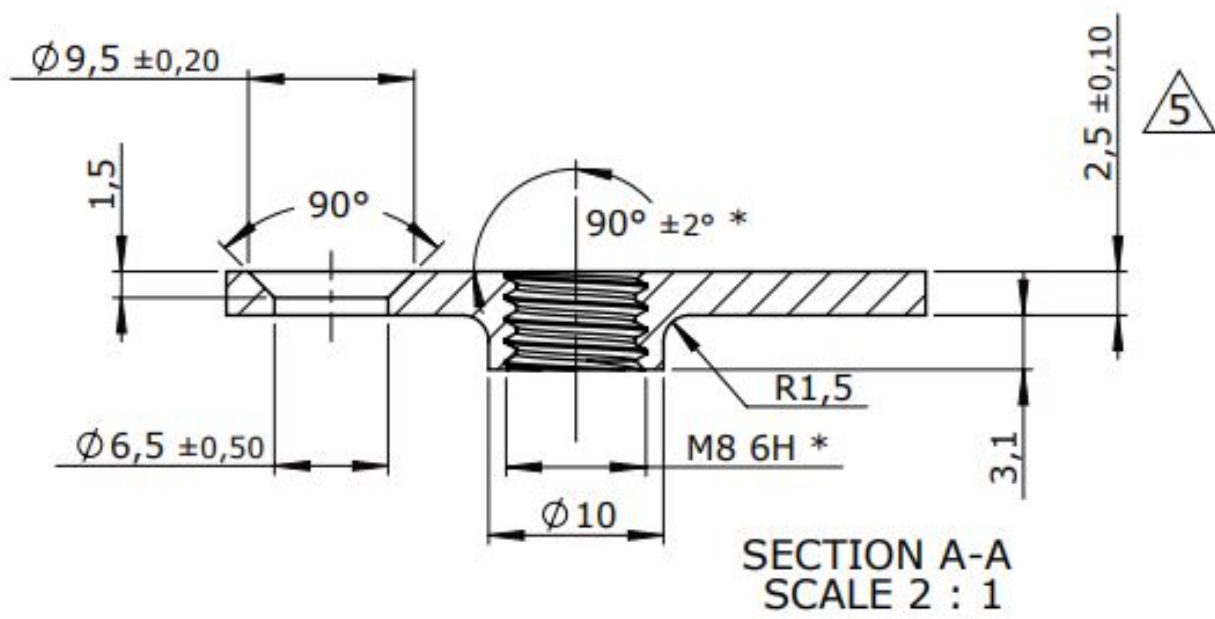

Measuring point



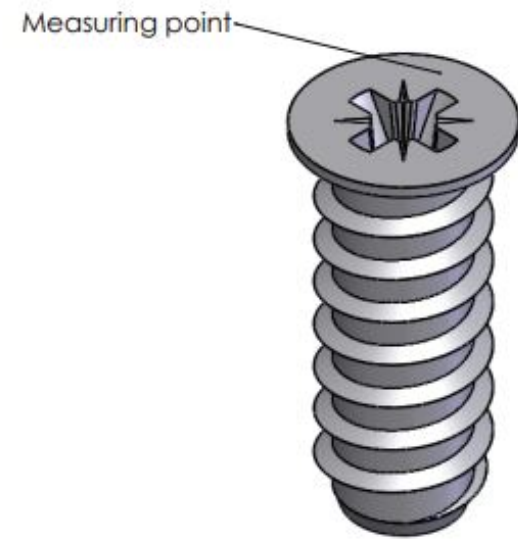
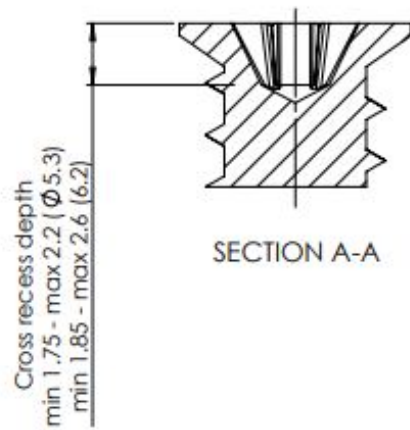
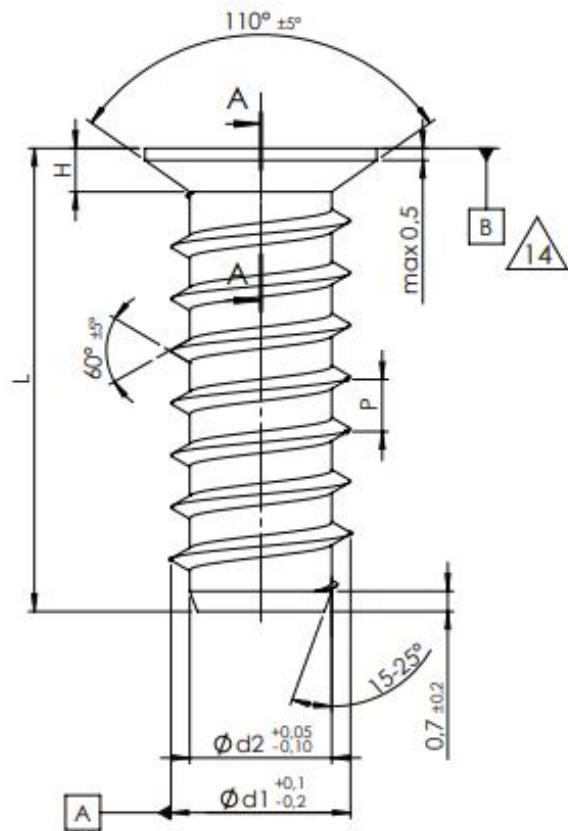

Ød1	Ød2	ØD	H	P
6,2	4,95	8	1.5 ±0.15	1.8
5,3	3,3	7	1.2 ±0.15	2

